

Either voltage source is suitable,  
only one is required.

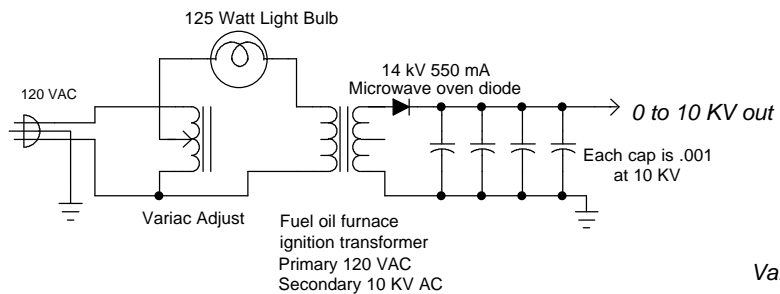

**CAUTION: secondary center tap is connected to transformer case.**

**Fuel oil furnace inition transformer voltage source**

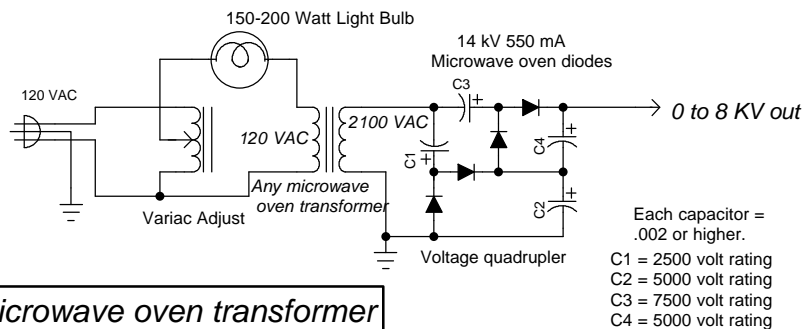

**Microwave oven transformer voltage source**

Lower wattage light bulbs will glow brightly and inhibit greater voltage output with the microwave oven transformer at around 8 KV out. This varies with each transformer, and is caused by the relatively high saturating current typical of this kind of transformer. To increase the output voltage without excessive current limiting, simply increase the light bulb wattage.

# DANGER HIGH VOLTAGE

**High voltage leakage detector and metering circuit**

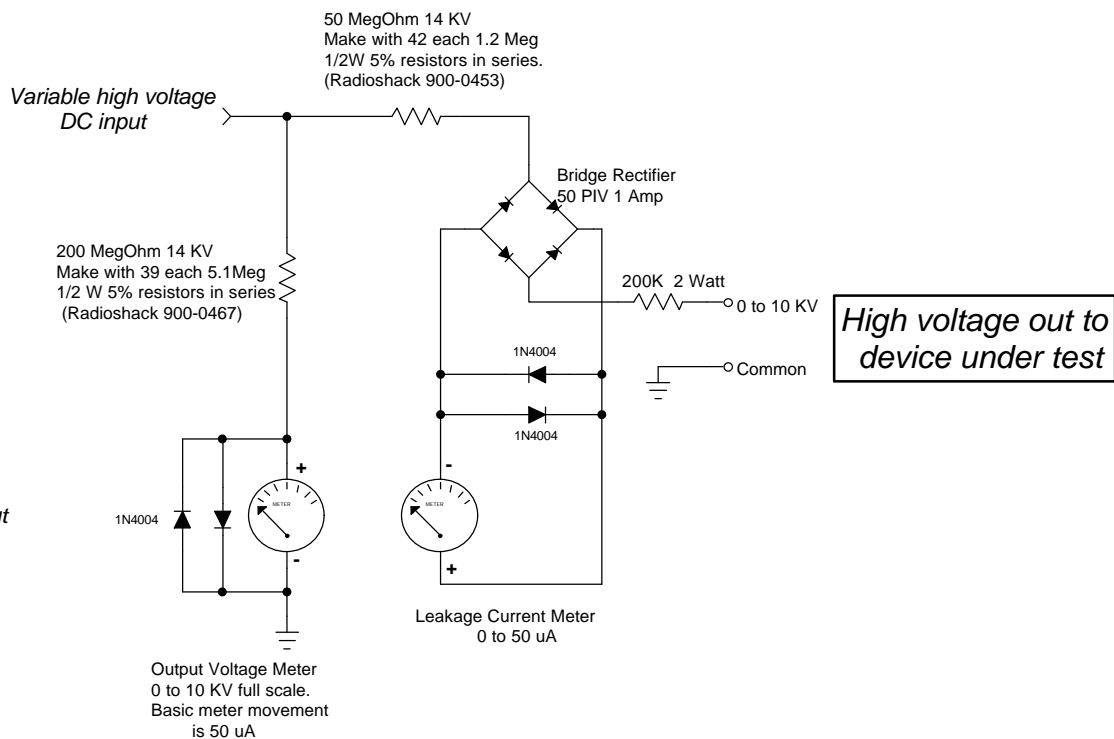

## High Voltage Breakdown Tester

<b>DRAWN BY:</b> Bill Jones K8CU	
<b>PAGE</b> 1 of 1	<b>DATE:</b> 5-17-2002